

SECTION A-A

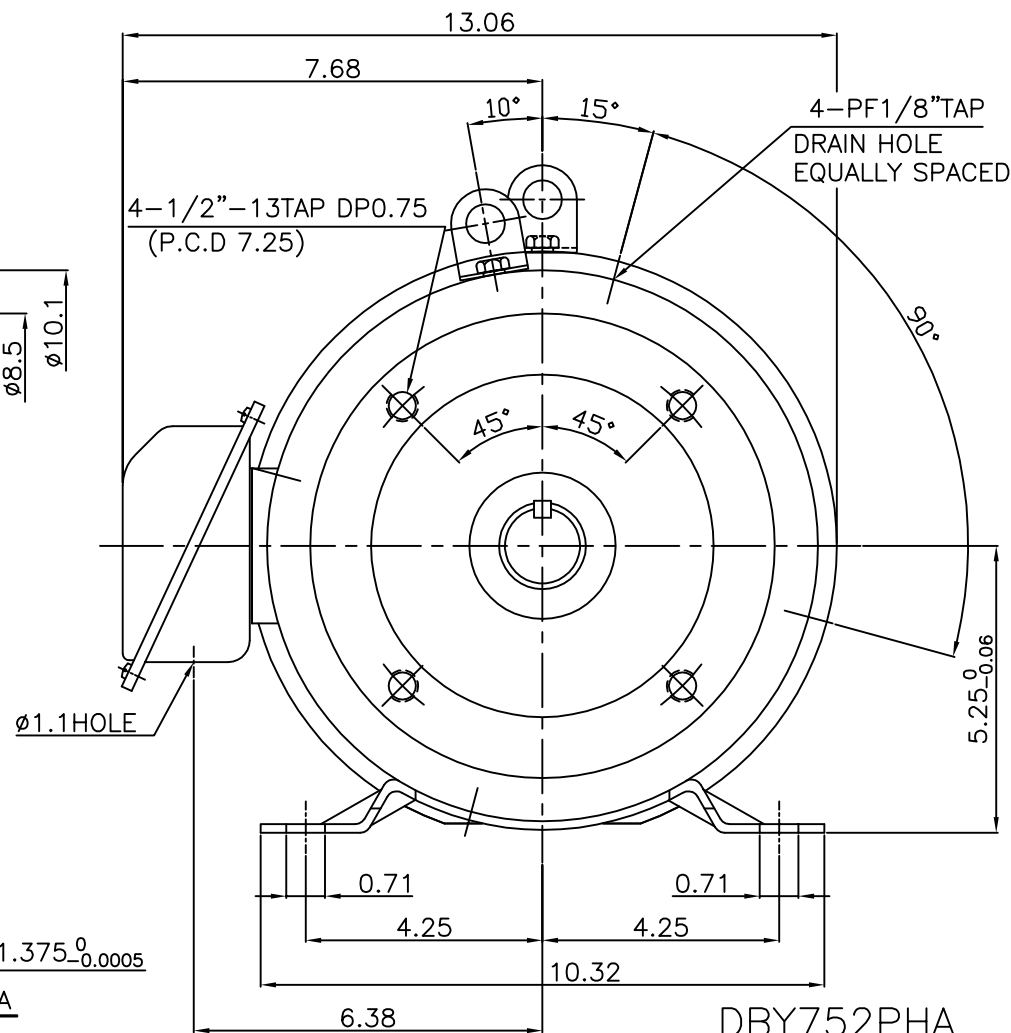

DBY752PHA
 DHY752PHA
 DIY752PHI

STERLING ELECTRIC, INC. INDIANAPOLIS, IN	OUTLINE 3-PHASE ROLLED STEEL MOTOR	DESIGNED		DIMENSIONS IN INCHES
		CHECKED		3RD ANGLE PROJECTION
		APPROVED		DWG. NO: DBY752~DHY752PHI